

A/133/V-10 High Temperature, Water cooled Piezoelectric IEPE Triaxial Accelerometer

1mV/g up to 250mV/g $\pm 10\%$ 46gms
900°C max surface temperature *with water flow*

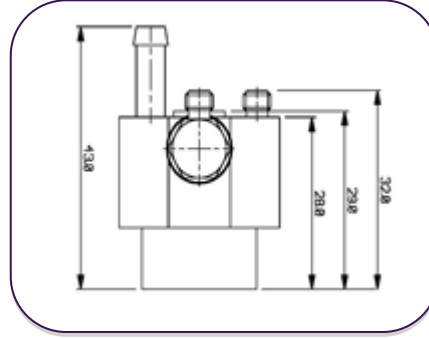

A/133/V-10

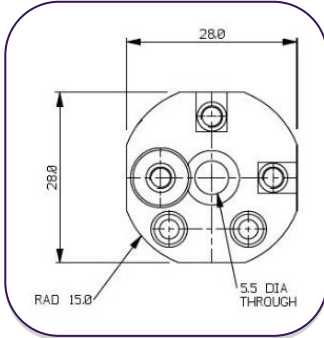

Options

A/133/V-3 – flat base block for mounting on flat surfaces
A/133V-10 – raised base for customer modification on curved or irregular shaped mounting surface

The A/133/V IEPE range of voltage triaxial accelerometers feature ultra high temperature usage on surfaces up to 900°C. Developed as solutions for Vibration Measurements on exhaust pipes or engine turbo collectors, they have since found uses in many other high temperature test applications.

Mono-axial versions can also be supplied on request, axis selection to suit customer application.

Water flow is via two titanium pipes and it's recommended that the flow rate of 0.5 litres/min is maintained permanently when in use at high temperature. Failure to do so could lead to injury and damage to the unit.

It is recommended at the highest temperatures a constant supply of chilled cooling water should be used.

The A/133/V consists of 3 mono axial voltage accelerometers mounted into an anodized aluminium block. This allows the advantage of single axis repair if required.

Accessories:
Silicone tubing
General purpose 12V pump

Typical Frequency Response

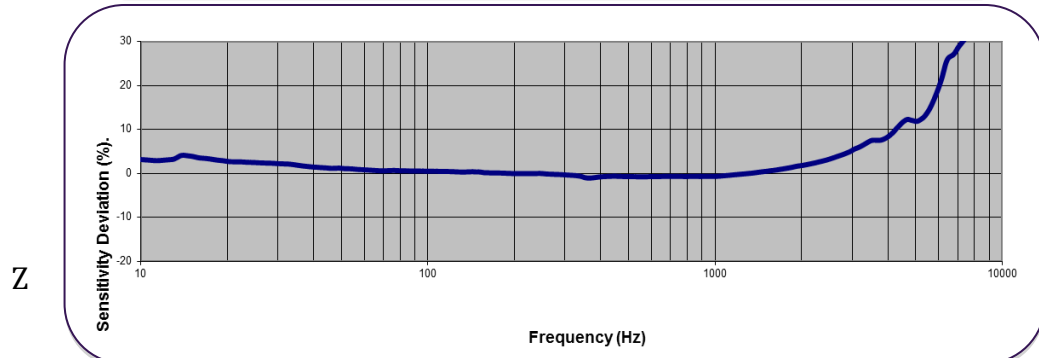
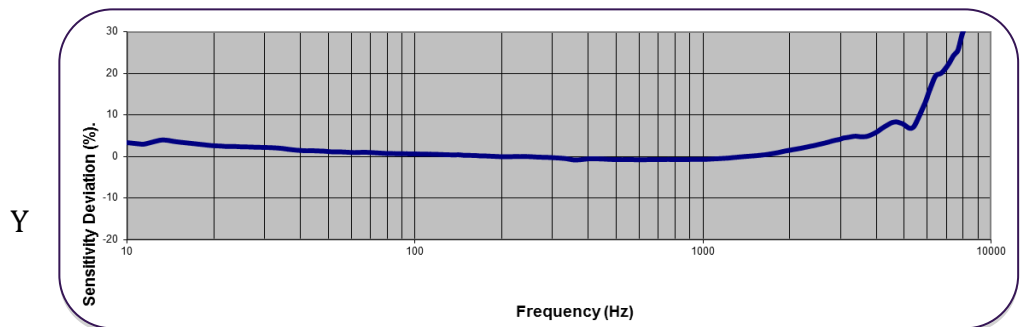
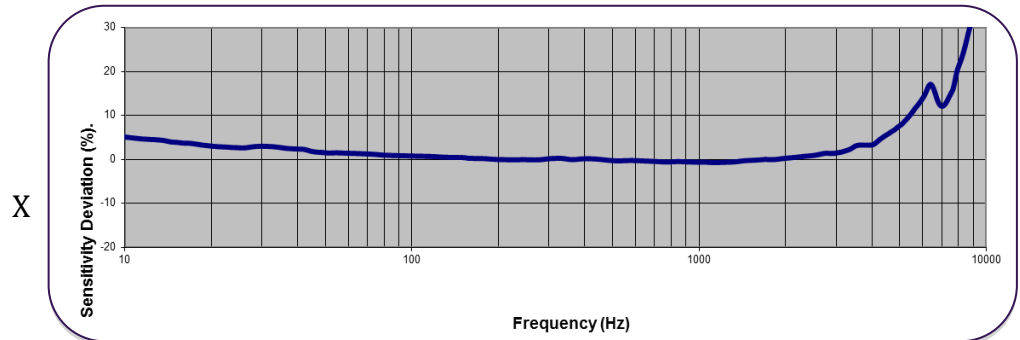

Please note: For information and reference only. Data should not be used as pass / fail criteria for calibration purposes

A/133/V-10 High Temperature, Water cooled Piezoelectric IEPE Triaxial Accelerometer

1mV/g up to 250mV/g $\pm 10\%$ 38gms
 900°C max surface temperature *with water flow*



Temperature Response

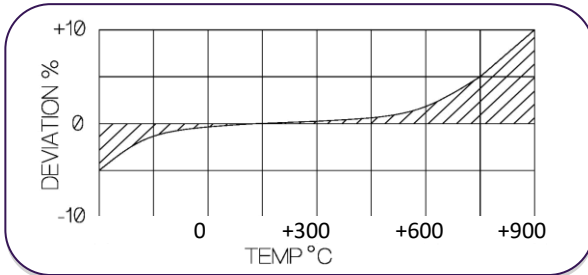

Spectral Noise

1Hz	761 $\mu\text{g}/\sqrt{\text{Hz}}$
10Hz	193 $\mu\text{g}/\sqrt{\text{Hz}}$
100Hz	37.8 $\mu\text{g}/\sqrt{\text{Hz}}$
1kHz	11.2 $\mu\text{g}/\sqrt{\text{Hz}}$
10kHz	4.2 $\mu\text{g}/\sqrt{\text{Hz}}$

	Metric		Imperial	
	Voltage sensitivity $\pm 10\%$	1.02 mV/(m/s ²)	10.2 mV/(m/s ²)	10 mV/g
Resonant Frequency	$\approx 15\text{kHz}$			
Typical Frequency Range $\pm 5\%$ $\pm 10\%$	1Hz - 3kHz 0.7Hz - 4kHz			
Cross Axis error	$\leq 5\%$ max			
Temperature Range <i>Without water flow</i> <i>With water flow</i>	-50/ +125°C +900°C (surface temp)		-58/ +257°F +1652°F (surface temp)	
Max continuous accn. g sine	4903m/s ²	490m/s ²	500g	50g
Supply voltage	15/35 VDC			
Supply current	2/20mA			
Bias voltage (20°C / 68°F)	10/14 VDC			
Setting time within 10% bias	≤ 3 sec			
Broadband resolution gms	0.003			
Base Strain Sensitivity	$\leq 0.001\text{g}/\mu$ strain			
Case Material	Inserts s/steel 303 S31 Mtg. block anodised al. alloy			
Mounting	1 x $\text{Ø}2.22\text{mm}$ through hole			
Weight	46gms		1.62oz	
Case seal	Welded inserts bonded into hard anodized aluminium body			
Size	28 x 28 x 42mm		1.1 x 1.1 x 1.65in	
Connector	3 x 10-32 UNF Microdot			

Please note: For information and reference only. Data should not be used as pass / fail criteria for calibration purposes